



Uppgiftslämnaren reserverar sig för eventuella fel i produktinformationen eller felaktigt registrerade uppgifter och förbehåller sig rätten att korrigera och/eller komplettera produktinformation utan föregående avisering

## 1 GRUNDDATA

### Varubeskrivning

Radiatorventiler och reservdelar tillverkade i mässingslegering innehållande mindre än 0.1% bly.

### Övriga upplysningar

#### Klassificeringar

ETIM >	
BK04 >	
BSAB >	
UNSPSC >	

### Leverantörsuppgifter

#### Företagsnamn

Danfoss AB

#### Organisationsnummer

5560523903

#### Adress

Industrigatan 5

#### Hemsida

www.danfoss.se

#### Miljökontaktperson

##### Namn

Anders Gustavsson

##### Telefon

+46 104400242

##### E-post

anders.gustavsson@danfoss.com

## 2 HÅLLBARHETSARBETE

### Företagets certifiering

- ISO 9001

### 3 INNEHÅLLSDEKLARATION

Kemisk produkt	Nej
Innehåller produkten elektronik	Nej
Omfattas varan av RoHS-direktivet	Nej
Varans vikt	0,14 - 0,26 kg

#### Vara / Delkomponenter

Koncentrationen har beräknats på hela varan

Ingående material /komponenter	Vikt-% i komponent	CAS-nr (alt legering)	EG-nr (alt legering)	Vikt % i produkt	Kommentar
Unisilikon L641				0,05%	
Syntheso proba 330				0,1%	
Zink		7440-66-6	231-175-3	1,8%	
Mässing CW452K (CuSn6), Pb ≤0,02%		Övrigt, metaller		0,4%	
Akrylonitril-butadien polymer (NBR) synonym 1,3-Butadien-akrylonitril polymer		9003-18-3		0,2%	
EPDM		Övrigt, polymer		0,5%	
Poly(thiophenylene), PPS, Poly(phenylene sulfide), polyphenylene sulfure		9016-75-5		3%	
Polypropen (PP)		9003-07-0		3%	
Mässing CW724R* (CuZn21Si3P) Pb ≤ 0,1% , Ni ≤ 0,2% (*=4MS B,C)		Övrigt, metaller		90%	

Del av materialinnehållet som är deklarerat 99,05%

#### Särskilt farliga ämnen

Varan innehåller INTE några ämnen med särskilt farliga egenskaper (Substances of very high concern, SVHC-ämnen) som finns med på kandidatförteckningen i en koncentration som överstiger 0,1 vikts-%

Utgåva av kandidatförteckningen som har använts

2022-11-14

#### Nanomaterial

Innehåller produkten tillsatt nanomaterial, som är medvetet tillsatta för att uppnå en viss funktion?: Nej

#### Tillsatt högflourerade ämnen (PFAS)

Innehåller produkten tillsatt högflourerade ämnen (PFAS), som är aktivt tillsatta för att uppnå en specifik funktion?: Nej

#### Övrigt

Ämnen är redovisade ned till 0,1% viktprocent enligt iBVDs redovisningskrav. Eventuell avvikelser från redovisningskraven redovisas nedan

## 4 RÅVAROR

#### Återvunnet material

Innehåller varan återvunnet material: Nej

#### Träråvara

Träråvara ingår i varan: Nej

## 5 MILJÖPÅVERKAN

Finns en miljövarudeklaration framtagen enligt EN15804 eller ISO14025 för varan

Nej

Finns annan miljövarudeklaration

Nej

## 6 DISTRIBUTION

Beskrivning av emballagehantering för distribution av varan

levereras i pappkartong

## 7 BYGGSCHEDET

Ställer varan särskilda krav vid lagring?

Ja

inomhus

Ställer varan särskilda krav på omgivande byggvaror?

Nej

8

**BRUKSSKEDET**

Finns skötselanvisningar/skötselråd?	Ja
Finns en energimärkning enligt energimärkningsdirektivet (2017/1369/EU) för varan?	Ej relevant

9

**RIVNING**

Kräver varan särskilda åtgärder för skydd av hälsa och miljö vid rivning/demontering?	Nej
---	-----

10

**AVFALLSHANTERING**

Omfattas den levererade varan av förordningen (2014:1075) om producentansvar för elektriska och elektroniska produkter när den blir avfall?	Nej
Är återanvändning möjlig för hela eller delar av varan?	Nej
Är materialåtervinning möjlig för hela eller delar av varan?	Ja
CW724R ca. 90 vikt% återvinningsbar	
Är energiåtervinning möjlig för hela eller delar av varan?	Nej
Har leverantören restriktioner och rekommendationer för återanvändning, material- eller energiåtervinning eller deponering?	Nej
När den levererade varan blir avfall, klassas den då som farligt avfall?	Nej
Avfallskod (EWC) för den levererade varan	Ej angivet

RSK-nummer	Eget Artikel-nr	GTIN
479 59 25	015G0071	5715162425367
479 59 26	015G0072	5715162425732
479 59 27	015G0073	5715162425749
479 59 28	015G0074	5715162425756
479 59 29	015G0076	5715162425763
479 59 30	015G3022	5715162425770
479 59 31	015G4022	5715162425787
481 21 48	015G3018	5702424635947
481 49 50	014G0287	5702425112881
481 21 49	015G3063	5702424635954

**Produktdatablad** RA-N RA-U PURE (AI403040432014se-000107).pdf

**Prestandadeklaration**

**Säkerhetsblad**

**RoHS-intyg**

**Miljövarudeklaration**

**Skötselanvisning** RA-N RA-U PURE (AI403040432014se-000107).pdf

**Övriga bifogade dokument**

-bvbs-app-LowleadSweden-20220516(AutoRecovered).pdf

## Datablad

# RA-N/RA-U PURE radiatorventiler med förinställning

### Användning



RA-N PURE rak

RA-N PURE vinkel

RA-U PURE

RA-N/RA-U PURE-ventilhusen är tillverkade av mässing som innehåller mindre än 0,1 % bly och är nickelpläterade.

Alla RA-N/RA-U PURE-ventilhus kan användas tillsammans med alla typer av radiatortermostater i RA 2000-serien och med TWA-A-termoställdon.

RA-N/RA-U PURE-ventiler används i tvårörsvärmsystem och finns i serie S.

RA-N/RA-U PURE-ventilerna har en  $k_v$ -begränsningsanordning för förinställning av maximalt vattenflöde och är tillgängliga med de inställningsområden som anges i nedanstående tabell.

Alla ventilhus har en skyddshatt som kan användas för manuell inställning under pågående byggnation. Hatten får inte användas som en manuell avstängningsanordning. En särskild del för manuell avstängning finns tillgänglig som tillbehör.

Packboxens tryckstift är tillverkat av metall med låg blyhalt och tillhörande O-ring är livstidsmörd. Det går att byta hela packboxen utan att först tömma systemet.

För att undvika avlagringar och korrosion måste värmevattnet uppfylla kraven i riktlinjen VDI 2035. Vi rekommenderar att undvika beredningar som innehåller mineralolja.

### Beställning och tekniska data

Typ	Konstruktion	Anslutningar		Förinställning								RSK nr	Best. nr	
		Tillopp Rp	Utlopp	$k_v$ -max. <sup>1)</sup> (m <sup>3</sup> /t vid $\Delta p = 1$ bar)										$k_{vs}$
				1	2	3	4	5	6	7	N			
RA-N PURE 10 med lås	Rak	3/8	M22 x 1.5	0,04	0,08	0,12	0,19	0,25	0,33	0,38	0,56	0,65	479 59 31	015G4022
RA-N PURE 10	Vinkel	3/8	M22 x 1.5	0,04	0,08	0,12	0,19	0,25	0,33	0,38	0,56	0,65	479 59 25	015G0071
	Rak	3/8	M22 x 1.5	0,04	0,08	0,12	0,19	0,25	0,33	0,38	0,56	0,65	479 59 26	015G0072
RA-N PURE 15	Vinkel	1/2	M26 x 1.5	0,04	0,08	0,12	0,20	0,30	0,40	0,51	0,73	0,90	479 59 27	015G0073
	Rak	1/2	M26 x 1.5	0,04	0,08	0,12	0,20	0,30	0,40	0,51	0,73	0,90	479 59 28	015G0074
RA-N PURE 20	Rak	3/4	M34 x 1.5	0,10	0,15	0,17	0,26	0,35	0,46	0,73	1,04	1,40	479 59 29	015G0076

Typ	Konstruktion	Anslutning		Förinställning												RSK nr	Best. nr	
		Tillopp Rp	Utlopp	$k_v$ -max. <sup>1)</sup> (m <sup>3</sup> /t vid $\Delta p = 1$ bar)														$k_{vs}$
				1	2	3	4	5	6	7	8	9	10	11	N			
RA-U PURE 10 med lås	Rak	3/8	M22 x 1.5	0,016	0,025	0,035	0,05	0,06	0,08	0,10	0,12	0,16	0,21	0,26	0,28	0,30	479 59 30	015G3022

<sup>1)</sup>  $k_v$ -värdet anger vattenflödet (Q) i m<sup>3</sup>/t vid ett tryckfall ( $\Delta p$ ) över ventilen på 1 bar;  $k_v = Q : \sqrt{\Delta p}$ . Vid inställning N anges  $k_v$ -värdet enligt SS-EN 215 vid  $X_p = 2K$  vilket innebär att ventilen stängs vid en rumstemperatur som är 2 °C högre. Vid lägre inställningar minskas  $X_p$ -värdet till 0,5 K av inställningsvärde 1.  
 $k_{vs}$ -värdet anger flödet Q vid maximal lyfthöjd, dvs. vid en helt öppen ventil vid inställning N.

### Kvalitet











RA-N/RA-U PURE-ventilerna är certifierade enligt den europeiska standarden SS-EN 215.

Danfoss radiatortermostater tillverkas i fabriker utvärderade och certifierade av BVC (Bureau Veritas Certification) enligt ISO 9001 och ISO 14001.

## Datablad

## RA-N/RA-U PURE radiatorventiler med förinställning

### Tillbehör

Typ		RSK nr	Best. nr
	Förinställningsnyckel för RA-U-ventil och läsbar RA-N-ventil	481 82 11	013G3028
	Δp-verktyg för pumpoptimering	511 78 09	013G7861
	PFM100 mätinstrument	511 78 03	003L8260
	PURE packbox	481 21 47	015G0290
	PURE Serviceinsats, läsbar, RA-N 10	481 21 48	015G3018
	PURE Serviceinsats, RA-N 10	481 21 49	015G3063
	PURE Serviceinsats, RA-N 15	481 21 50	015G3073
	Insatsbytesverktyg basic		013G3085

### Förinställning

Förinställningsvärdena för RA-N/RA-U PURE-ventilerna kan justeras enkelt och exakt utan verktyg (fabriksinställning = N):

- Ta bort skyddshatten/radiatortermostaten
- Leta rätt på referensmarkeringen
- Lyft och vrid inställningsringen tills önskad förinställning är i linje med referensmarkeringen.

Förinställningen kan väljas i steg mellan 1 och 7. (För RA-U PURE 10 går förinställningen från 1 till 11.) Vid inställning N är ventilen helt öppen. Denna inställning kan användas som spolningsposition om systemet måste spolas på grund av föroreningar. I enrörsinstallationer måste inställningen N användas.

Inställningar utanför 1 till 7 och N ska undvikas.

När radiatortermostaten har monterats kan förinställningen inte ändras oavsiktligt.

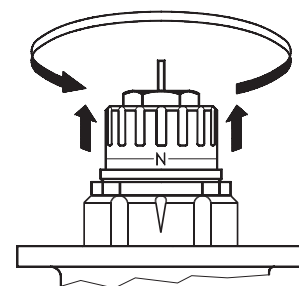

Fabriksinställning och ettrörs-system      Förinställningsområde

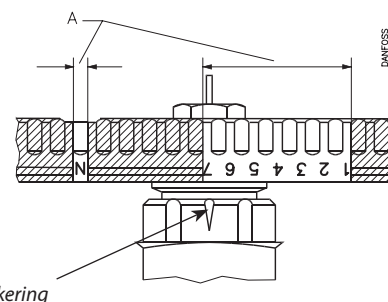



## Datablad

## RA-N/RA-U PURE radiatorventiler med förinställning

### Märkningar

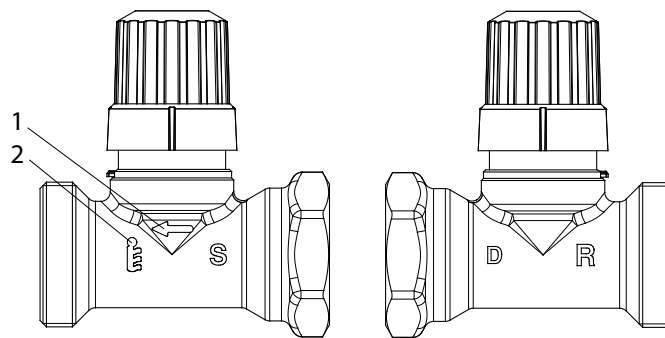

1. flödesriktning
2. Keymark
- S. svensk serie
- R. mindre än 0.1% bly
- D. Danfoss

### Funktionsprincip

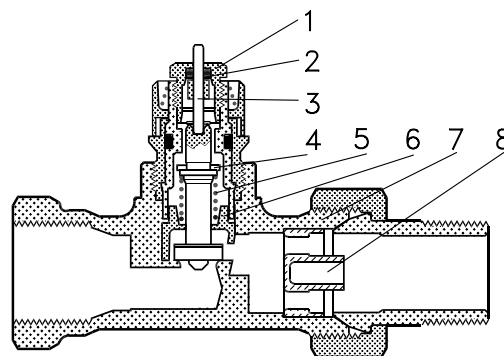

1. Packbox
2. O-ring
3. Tryckstift
4. Tätning
5. Reglerfjäder
6. Inställningsvred
7. Ventilhus
8.  $k_v$ -munstycke (endast 015G3022)

Radiatorventilerna består av termostater ur RA 2000-serien och ventilhuset RA-N/RA-U PURE. Radiatortermostat och ventilhus beställs var för sig.

Ventilens packbox kan bytas under drift, dvs. med vattenfyllt och trycksatt system.

Ventilhus och andra metalldelar	CW724R
Inställningsvred	PPS
O-ring	EPDM
Ventilkägla	NBR
Tryckstift och ventilfjäder	Kromstål
Munstycke	PP

Max. omgivande temperatur	60 °C
Max. medietemperatur	120 °C
Max. arbetstryck	10 bar
Max. differensstryck	0,6 bar
Provtryck	16 bar

Ventilhusen är förnicklade på utsidan.

Arbetstryck = statiskt + differensstryck. Det maximala differensstryck som anges är det maximala tryck vid vilket ventilerna ger tillfredsställande reglering. Brusljud kan uppstå under vissa flödes-/tryckförhållanden, vilket gäller alla anordningar som kan få trycket att falla. För tyst drift får det maximala tryckfallet inte överstiga 30 kPa för RA-N och 20 kPa för RA-U. Differensstrycket kan minskas med Danfoss differensstrycksregulatorer av typen AB-PM, ASV-P eller ASV-PV.

### Principer

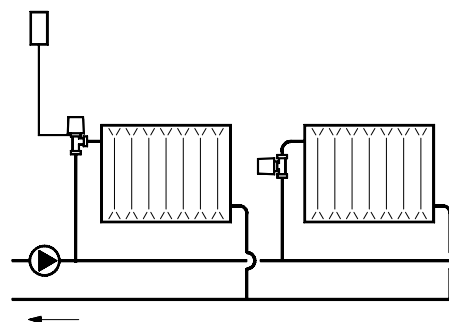

# Datablad

# RA-N/RA-U PURE radiatorventiler med förinställning

## Kapacitet

### RA-N PURE 10, R<sub>p</sub> 3/8-anslutning

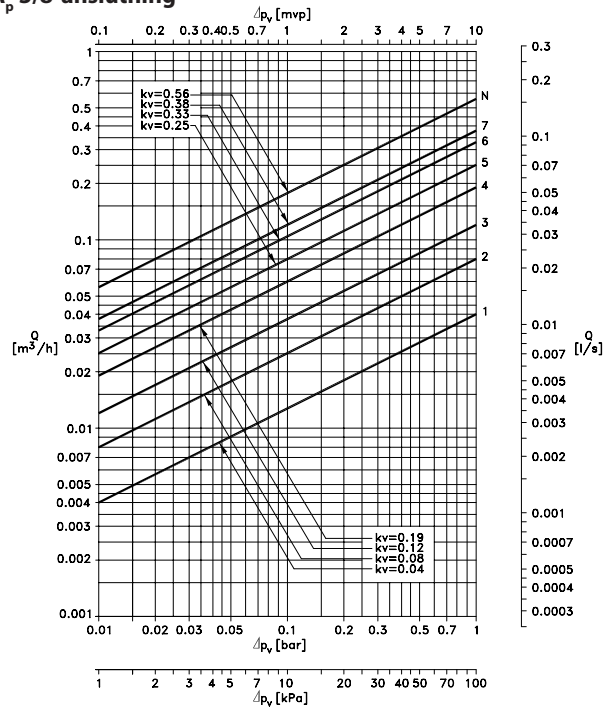

### RA-N PURE 15, R<sub>p</sub> 1/2-anslutning

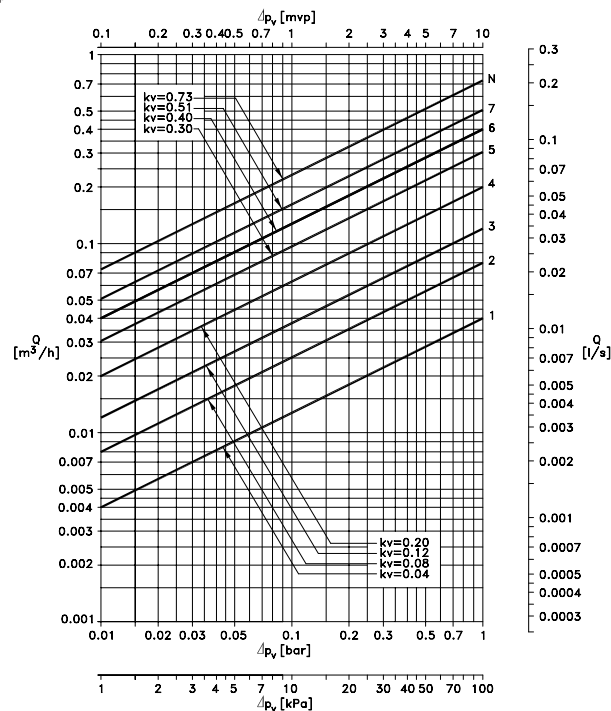

### Dimensioneringsexempel:

Värmebehov:	0,7 kW
Delta t över radiatorn:	20 °C
Flöde genom radiatorn:	$Q = \frac{0,7}{20 \times 1,16} = 0,03 \text{ m}^3/h = 0,0083 \text{ l/s}$
Tryckfall över ventilen:	$\Delta p = 10 \text{ kPa}$
Ventilinställning:	RA-N PURE 10      2
	RA-N PURE 15      2
	RA-N PURE 20      1

Det går också att hitta lämplig inställning direkt i tabellen "Beställning och tekniska data".

$$k_v = \frac{Q \text{ (m}^3/h\text{)}}{\sqrt{\Delta p \text{ (bar)}}$$

RA-N PURE 20, R<sub>p</sub> 3/4

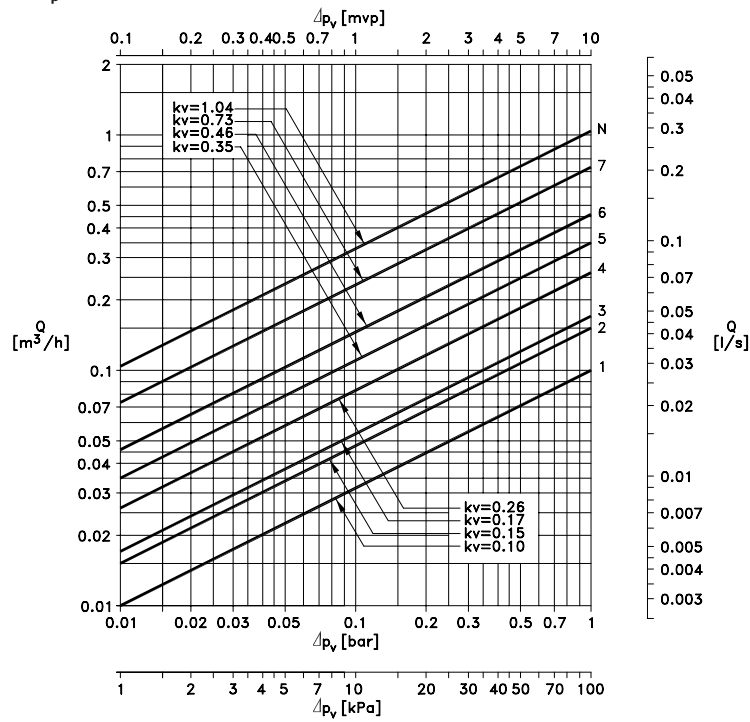

RA-U PURE 10, R<sub>p</sub> 3/8-anslutning

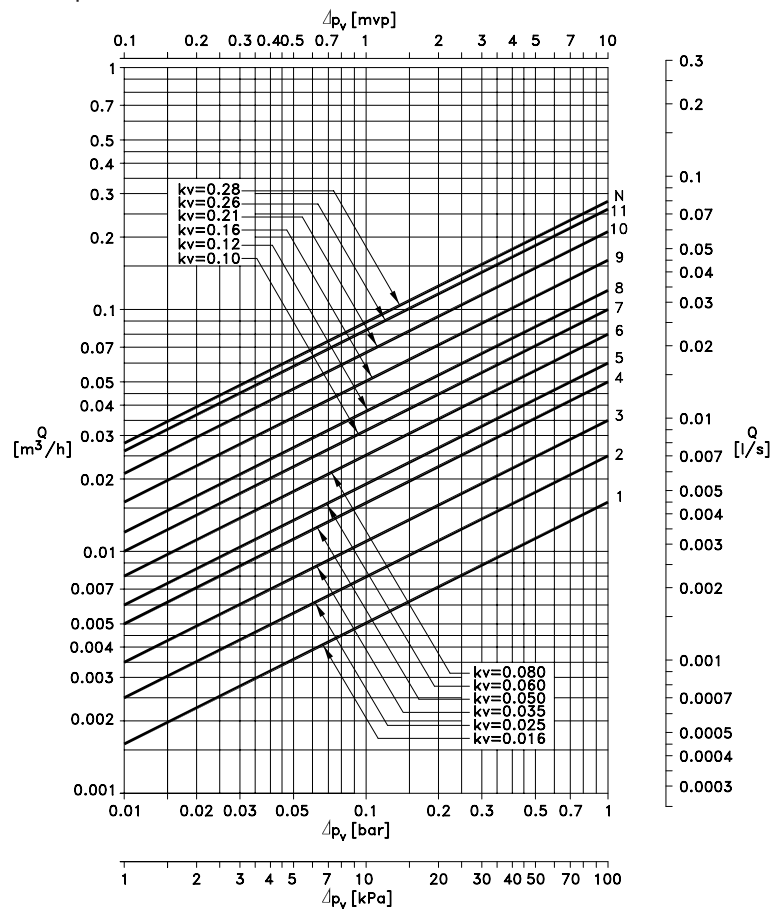

## Mått

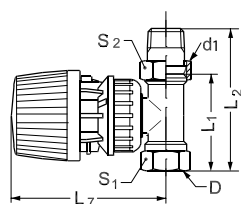

Rak ventil med radiatortermostat RA 2990

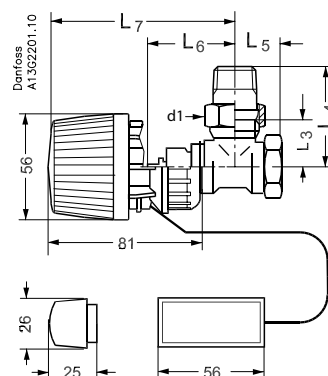

Vinkelventil med radiatortermostat RA 2992

Typ	ISO 7-1			L <sub>1</sub>	L <sub>2</sub>	L <sub>3</sub>	L <sub>4</sub>	L <sub>5</sub>	L <sub>6</sub>	L <sub>7</sub>	Över plana ytor	
	DN	D	d1								S <sub>1</sub>	S <sub>2</sub>
RA-N PURE 10	10	Rp3/8	M22 x 1.5	50	75	24	49	20	47	96	22	27
RA-N PURE 15	15	Rp1/2	M26 x 1.5	55	82	26	53	23	47	96	27	30
RA-N PURE 20	20	Rp3/4	M34 x 1.5	65	98	30	63	26	52	101	32	37
RA-U PURE 10	10	Rp3/8	M22 x 1.5	50	75					96	23	27

## Danfoss AB

Climate Solutions • danfoss.se • +46 10 88 87 400 • kundservice.se@danfoss.com

All information, inklusive men inte begränsat till information om val av produkt, produktens tillämpning eller användning, konstruktion, vikt, mått, kapacitet eller andra tekniska data i produktböcker, katalogbeskrivningar, annonser o.s.v., och oavsett om dessa tillhandahålls skriftligen, muntligen, elektroniskt, online eller via nedladdning, ska betraktas som informativ och är endast bindande om och i den utsträckning uttryckliga hänvisningar görs i en offert eller orderbekräftelse. Danfoss ansvarar inte för eventuella fel i kataloger, broschyrer, videor och annat material. Danfoss förbehåller sig rätten att ändra sina produkter utan föregående meddelande. Detta gäller även produkter som redan är beställda under förutsättning att sådana ändringar kan göras utan att efterföljande ändringar krävs i redan överenskomna specifikationer. Alla varumärken i detta material ägs av Danfoss A/S eller Danfoss-koncernens företag. Danfoss och Danfoss logotyp är varumärken som tillhör Danfoss A/S. Med ensamrätt.

## Datablad

# RA-N/RA-U PURE radiatorventiler med förinställning

### Användning



RA-N PURE rak

RA-N PURE vinkel

RA-U PURE

RA-N/RA-U PURE-ventilhusen är tillverkade av mässing som innehåller mindre än 0,1 % bly och är nickelpläterade.

Alla RA-N/RA-U PURE-ventilhus kan användas tillsammans med alla typer av radiatortermostater i RA 2000-serien och med TWA-A-termoställdon.

RA-N/RA-U PURE-ventiler används i tvårörsvärmsystem och finns i serie S.

RA-N/RA-U PURE-ventilerna har en  $k_v$ -begränsningsanordning för förinställning av maximalt vattenflöde och är tillgängliga med de inställningsområden som anges i nedanstående tabell.

Alla ventilhus har en skyddshatt som kan användas för manuell inställning under pågående byggnation. Hatten får inte användas som en manuell avstängningsanordning. En särskild del för manuell avstängning finns tillgänglig som tillbehör.

Packboxens tryckstift är tillverkat av metall med låg blyhalt och tillhörande O-ring är livstidsmörd. Det går att byta hela packboxen utan att först tömma systemet.

För att undvika avlagringar och korrosion måste värmevattnet uppfylla kraven i riktlinjen VDI 2035. Vi rekommenderar att undvika beredningar som innehåller mineralolja.

### Beställning och tekniska data

Typ	Konstruktion	Anslutningar		Förinställning								RSK nr	Best. nr	
		Tillopp Rp	Utlopp	$k_v$ -max. <sup>1)</sup> (m <sup>3</sup> /t vid $\Delta p = 1$ bar)										$k_{vs}$
				1	2	3	4	5	6	7	N			
RA-N PURE 10 med lås	Rak	3/8	M22 x 1.5	0,04	0,08	0,12	0,19	0,25	0,33	0,38	0,56	0,65	479 59 31	015G4022
RA-N PURE 10	Vinkel	3/8	M22 x 1.5	0,04	0,08	0,12	0,19	0,25	0,33	0,38	0,56	0,65	479 59 25	015G0071
	Rak	3/8	M22 x 1.5	0,04	0,08	0,12	0,19	0,25	0,33	0,38	0,56	0,65	479 59 26	015G0072
RA-N PURE 15	Vinkel	1/2	M26 x 1.5	0,04	0,08	0,12	0,20	0,30	0,40	0,51	0,73	0,90	479 59 27	015G0073
	Rak	1/2	M26 x 1.5	0,04	0,08	0,12	0,20	0,30	0,40	0,51	0,73	0,90	479 59 28	015G0074
RA-N PURE 20	Rak	3/4	M34 x 1.5	0,10	0,15	0,17	0,26	0,35	0,46	0,73	1,04	1,40	479 59 29	015G0076

Typ	Konstruktion	Anslutning		Förinställning												RSK nr	Best. nr	
		Tillopp Rp	Utlopp	$k_v$ -max. <sup>1)</sup> (m <sup>3</sup> /t vid $\Delta p = 1$ bar)														$k_{vs}$
				1	2	3	4	5	6	7	8	9	10	11	N			
RA-U PURE 10 med lås	Rak	3/8	M22 x 1.5	0,016	0,025	0,035	0,05	0,06	0,08	0,10	0,12	0,16	0,21	0,26	0,28	0,30	479 59 30	015G3022

<sup>1)</sup>  $k_v$ -värdet anger vattenflödet (Q) i m<sup>3</sup>/t vid ett tryckfall ( $\Delta p$ ) över ventilen på 1 bar;  $k_v = Q : \sqrt{\Delta p}$ . Vid inställning N anges  $k_v$ -värdet enligt SS-EN 215 vid  $X_p = 2K$  vilket innebär att ventilen stängs vid en rumstemperatur som är 2 °C högre. Vid lägre inställningar minskas  $X_p$ -värdet till 0,5 K av inställningsvärde 1.  
 $k_{vs}$ -värdet anger flödet Q vid maximal lyfthöjd, dvs. vid en helt öppen ventil vid inställning N.

### Kvalitet











RA-N/RA-U PURE-ventilerna är certifierade enligt den europeiska standarden SS-EN 215.

Danfoss radiatortermostater tillverkas i fabriker utvärderade och certifierade av BVC (Bureau Veritas Certification) enligt ISO 9001 och ISO 14001.

## Datablad

## RA-N/RA-U PURE radiatorventiler med förinställning

### Tillbehör

Typ		RSK nr	Best. nr
	Förinställningsnyckel för RA-U-ventil och läsbar RA-N-ventil	481 82 11	013G3028
	Δp-verktyg för pumpoptimering	511 78 09	013G7861
	PFM100 mätinstrument	511 78 03	003L8260
	PURE packbox	481 21 47	015G0290
	PURE Serviceinsats, läsbar, RA-N 10	481 21 48	015G3018
	PURE Serviceinsats, RA-N 10	481 21 49	015G3063
	PURE Serviceinsats, RA-N 15	481 21 50	015G3073
	Insatsbytesverktyg basic		013G3085

### Förinställning

Förinställningsvärdena för RA-N/RA-U PURE-ventilerna kan justeras enkelt och exakt utan verktyg (fabriksinställning = N):

- Ta bort skyddshatten/radiatortermostaten
- Leta rätt på referensmarkeringen
- Lyft och vrid inställningsringen tills önskad förinställning är i linje med referensmarkeringen.

Förinställningen kan väljas i steg mellan 1 och 7. (För RA-U PURE 10 går förinställningen från 1 till 11.) Vid inställning N är ventilen helt öppen. Denna inställning kan användas som spolningsposition om systemet måste spolas på grund av föroreningar. I enrörsinstallationer måste inställningen N användas.

Inställningar utanför 1 till 7 och N ska undvikas.

När radiatortermostaten har monterats kan förinställningen inte ändras oavsiktligt.

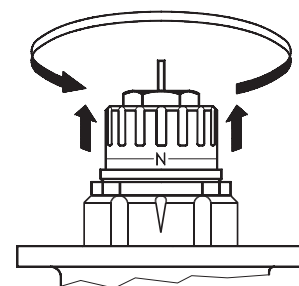

Fabriksinställning och ettrörs-system      Förinställningsområde

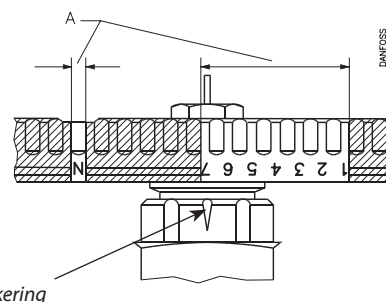

## Datablad

## RA-N/RA-U PURE radiatorventiler med förinställning

### Märkning

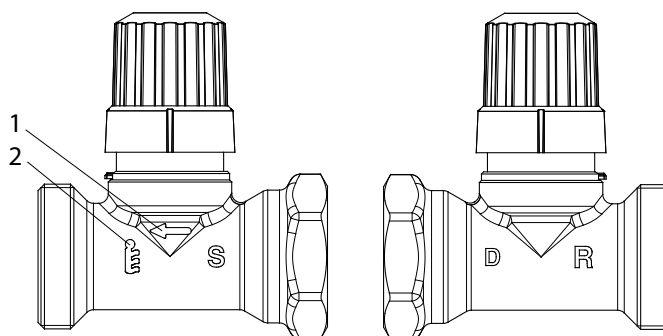

1. flödesriktning
2. Keymark
- S. svensk serie
- R. mindre än 0.1% bly
- D. Danfoss

### Funktionsprincip

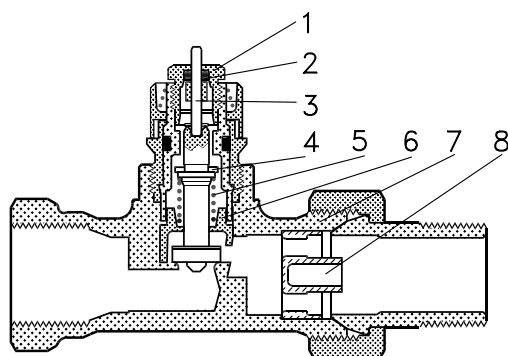

1. Packbox
2. O-ring
3. Tryckstift
4. Tätning
5. Reglerfjäder
6. Inställningsvred
7. Ventilhus
8.  $k_v$ -munstycke (endast 015G3022)

Radiatorventilerna består av termostater ur RA 2000-serien och ventilhuset RA-N/RA-U PURE. Radiatortermostat och ventilhus beställs var för sig.

Ventilens packbox kan bytas under drift, dvs. med vattenfyllt och trycksatt system.

Ventilhus och andra metalldelar	CW724R
Inställningsvred	PPS
O-ring	EPDM
Ventilkägla	NBR
Tryckstift och ventilfjäder	Kromstål
Munstycke	PP

Max. omgivande temperatur	60 °C
Max. medietemperatur	120 °C
Max. arbetstryck	10 bar
Max. differensstryck	0,6 bar
Provtryck	16 bar

Ventilhusen är förnicklade på utsidan.

Arbetstryck = statiskt + differensstryck. Det maximala differensstryck som anges är det maximala tryck vid vilket ventilerna ger tillfredsställande reglering. Brusljud kan uppstå under vissa flödes-/tryckförhållanden, vilket gäller alla anordningar som kan få trycket att falla. För tyst drift får det maximala tryckfallet inte överstiga 30 kPa för RA-N och 20 kPa för RA-U. Differensstrycket kan minskas med Danfoss differensstrycksregulatorer av typen AB-PM, ASV-P eller ASV-PV.

### Principer

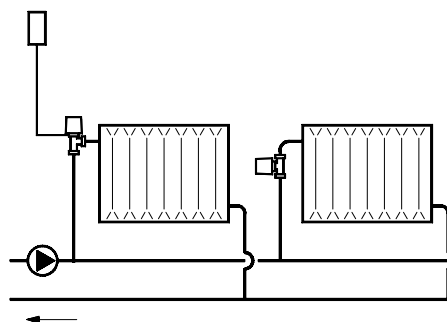

# Datablad

# RA-N/RA-U PURE radiatorventiler med förinställning

## Kapacitet

### RA-N PURE 10, R<sub>p</sub> 3/8-anslutning

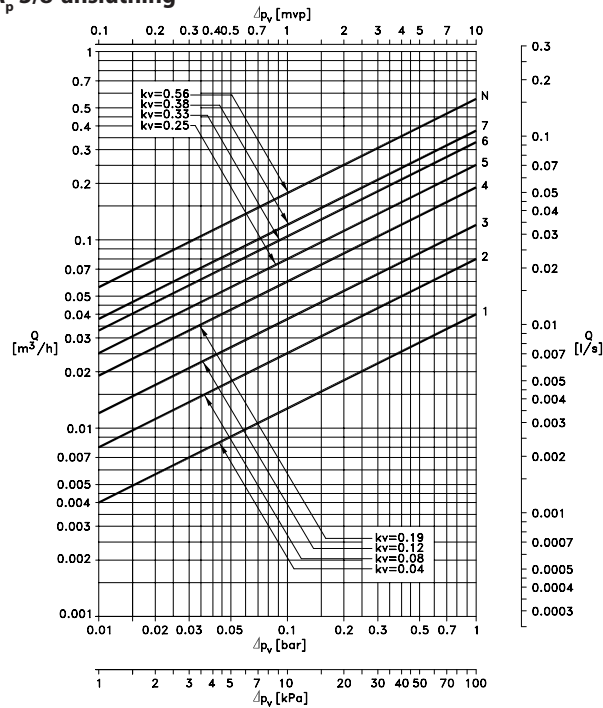

### RA-N PURE 15, R<sub>p</sub> 1/2-anslutning

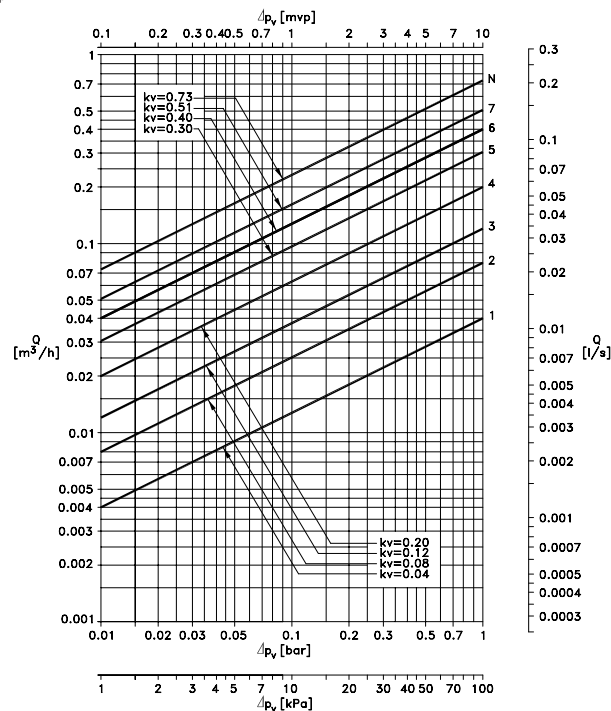

### Dimensioneringsexempel:

Värmebehov:	0,7 kW
Delta t över radiatorn:	20 °C
Flöde genom radiatorn:	$Q = \frac{0,7}{20 \times 1,16} = 0,03 m^3/h = 0,0083 l/s$
Tryckfall över ventilen:	$\Delta p = 10 kPa$
Ventilinställning:	RA-N PURE 10      2
	RA-N PURE 15      2
	RA-N PURE 20      1

Det går också att hitta lämplig inställning direkt i tabellen "Beställning och tekniska data".

$$k_v = \frac{Q (m^3/h)}{\sqrt{\Delta p (bar)}}$$



RA-N PURE 20, R<sub>p</sub> 3/4

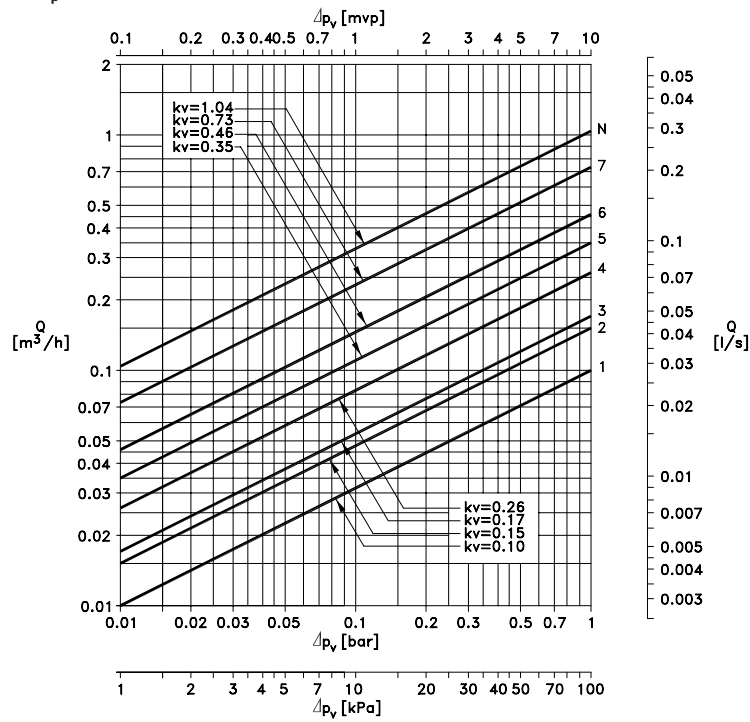

RA-U PURE 10, R<sub>p</sub> 3/8-anslutning

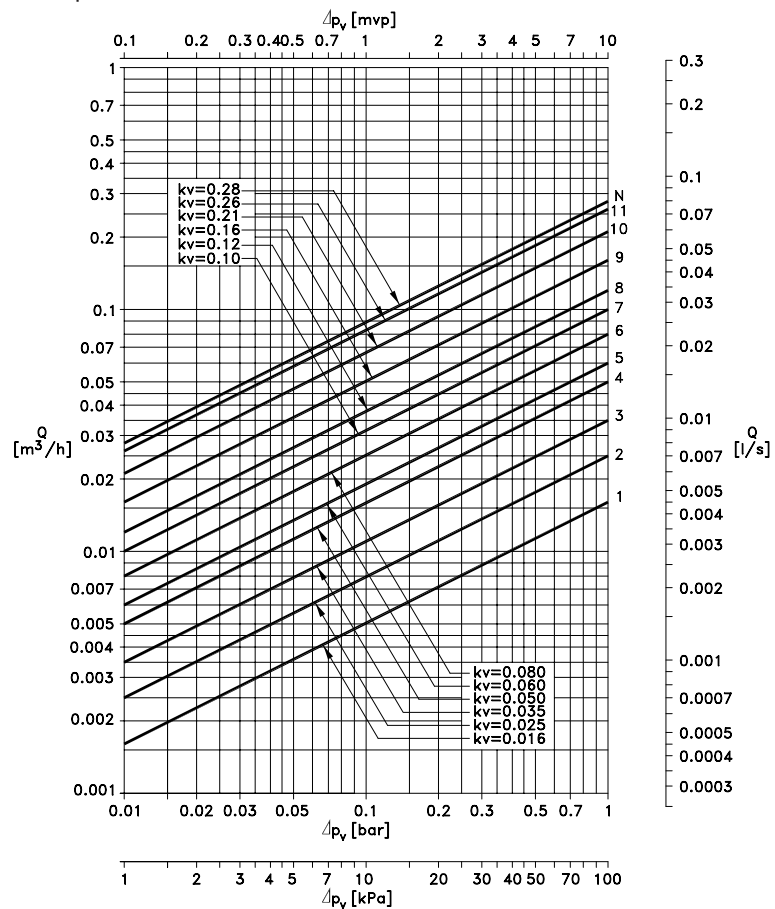

## Mått

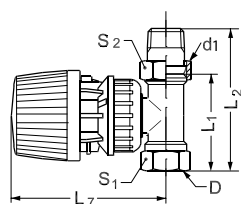

Rak ventil med radiatortermostat RA 2990

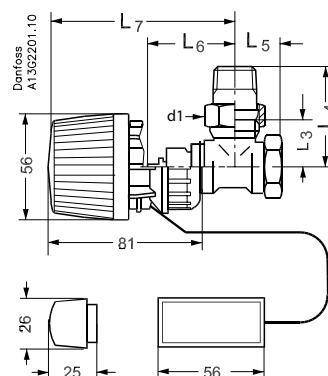

Vinkelventil med radiatortermostat RA 2992

Typ	ISO 7-1			L <sub>1</sub>	L <sub>2</sub>	L <sub>3</sub>	L <sub>4</sub>	L <sub>5</sub>	L <sub>6</sub>	L <sub>7</sub>	Över plana ytor	
	DN	D	d1								S <sub>1</sub>	S <sub>2</sub>
RA-N PURE 10	10	Rp3/8	M22 x 1.5	50	75	24	49	20	47	96	22	27
RA-N PURE 15	15	Rp1/2	M26 x 1.5	55	82	26	53	23	47	96	27	30
RA-N PURE 20	20	Rp3/4	M34 x 1.5	65	98	30	63	26	52	101	32	37
RA-U PURE 10	10	Rp3/8	M22 x 1.5	50	75					96	23	27

## Danfoss AB

Climate Solutions • danfoss.se • +46 10 88 87 400 • kundservice.se@danfoss.com

All information, inklusive men inte begränsat till information om val av produkt, produktens tillämpning eller användning, konstruktion, vikt, mått, kapacitet eller andra tekniska data i produkt-handböcker, katalogbeskrivningar, annonser o.s.v., och oavsett om dessa tillhandahålls skriftligen, muntligen, elektroniskt, online eller via nedladdning, ska betraktas som informativ och är endast bindande om och i den utsträckning uttryckliga hänvisningar görs i en offert eller orderbekräftelse. Danfoss ansvarar inte för eventuella fel i kataloger, broschyurer, videor och annat material. Danfoss förbehåller sig rätten att ändra sina produkter utan föregående meddelande. Detta gäller även produkter som redan är beställda under förutsättning att sådana ändringar kan göras utan att efterföljande ändringar krävs i redan överenskomna specifikationer. Alla varumärken i detta material ägs av Danfoss A/S eller Danfoss-koncernens företag. Danfoss och Danfoss logotyp är varumärken som tillhör Danfoss A/S. Med ensamrätt.

## Byggvarubedömningen's guidelines and information requirements for assessment of products, Version 2021-1.

These guidelines describe what information Byggvarubedömningen requires for assessment of articles and chemical products. Information about the article or chemical product can be provided in this document, alternatively refer to another documentation in which the corresponding information is given. For certain types of articles and chemical products additional information may be requested.

### 1. Product information

#### Product

Product name:	RA-N & RA-U Pure and accessories	
Article No.: <i>Specify the type of number, e.g. RSK, E-number, EAN, GTIN or supplier's article number. This should also be stated on the application.</i>	015G0071; 015G0072; 015G0073; 015G0074; 015G0076; 015G3022; 015G4022, 015G0290, 015G3018, 015G3063, 015G3073.	
Product description: <i>Upon application, please attach a products data sheet, or similar.</i>	Radiator valves for water based heating systems. To be mounted on radiators, convectors, e.g.	
Type of product:	<input type="checkbox"/> Chemical product	<input checked="" type="checkbox"/> Article
Date (year, month, day) of preparation/revision:	2022-01-07	

#### Supplier/Manufacturer

Supplier:	Danfoss	
Manufacturer, if other than the supplier: <i>Voluntary information</i>		
Contact person:	Anders Gustavsson	
Address:	Danfoss AB SE 58199 Linköping	
E-mail:	anders.gustavsson@danfoss.com	
Phone number:	+46 10 440 02 42	

#### Supporting documentation

Has a declaration of performance in line with the European Construction Products	<input type="checkbox"/> Yes	<input checked="" type="checkbox"/> No
--	------------------------------	--

Regulation (EU) no 305/2011, been prepared for the product?		
If yes, attach the declaration of performance with the application.		
Is the article/product an electronic product and covered by the RoHS-directive (according to the version valid at the time of application)?	<input type="checkbox"/> Yes	<input checked="" type="checkbox"/> No
If yes, attach an "EU Declaration of Conformity", or alternatively another certificate that attests that the product corresponds to the requirements according to the latest version of the RoHS-directive, together with the application.		
If the article/product is an electronic product that is covered by an exemption according to the RoHS-directive, specify which exemption and date (year, month, day) when the exemption expires if time-limited:	Exemptions according to RoHS:  Date:	

## 2. Declaration of contents:

Please specify the full content of the article or the chemical product, *on delivery*, in Table 1, or alternatively attach other documentation that provides the corresponding information. For instructions, please refer to the "Annex 1. Declaration of content, Byggsvarubedömningen's reporting requirements, 2021-1", which is found at the end of this document.

**Table 1.** Contents of included substances and material (declaration of content in accordance with the requirements).

Included substances and materials	EC-/ CAS-number (alternatively, alloy number)	Weight% (of the entire product)	When applicable, state for which subcomponent	Weight% (of substance in subcomponent)	Comments (state any application of non-harmonized classifications)
Brass	CW724R	88-94%			
Plastic	PP, 30%GF	2-4%			
Plastic	PPS, 40%GF	2-4%			
Rubber	EPDM	0,5-0,9%			
Rubber	NBR	0,2-0,6%			
Stainless steel	1.4310	1-2%			
Tinbronze	CW452K	0,4-0,8%			
Zink	Z410	1,8-3,1%			
Grease	Syntheso Proba 330	0,1-0,3%			
Grease	Unisilikon L641	0,1-0,2%			
Nickel	Ni	0,05-0,1%			

If any deviations from Byggvarubedömningens declaration requirements exist, specify these in the comments in Table 1, or alternatively here.	Other comments: N.A.
--	-------------------------

Is the chemical composition different, for the product when applied (cured product) compared to the content at delivery? (Only for chemical products)	<input type="checkbox"/> Yes	<input checked="" type="checkbox"/> No
If yes, specify the content of the cured product in Table 2.		

**Table 2.** Contents for the applied product (full content in accordance with the declarations requirements)

Included substances and materials	EC-/ CAS-number	Weight% (of the applied product)	Comments (state any application of non-harmonized classifications)
If any deviations from Byggvarubedömningens declaration requirements exist, specify these in the comments in Table 1, or alternatively here.		Other comments:	

Does the product or any of its subcomponents contain substances with particularly hazardous properties (Substances of Very High Concern, SVHC-substances), which are included in the Candidate List at a concentration $\geq 0.1$ weight%?	<input type="checkbox"/> Yes	<input checked="" type="checkbox"/> No
If yes, specify these substances in Table 1 together with the rest of the content of the product.		
State the date (year, month, day) for control of the Candidate List.	Date: 2022.01.07	
The concentration is calculated at component level established on the principle "once a product, always a product". The Candidate List is available at: <a href="http://echa.europa.eu/sv/candidate-list-table">http://echa.europa.eu/sv/candidate-list-table</a> .		

### Nanomaterials

Does the product contain any nanomaterial that has been purposefully added to achieve a specific function?	<input type="checkbox"/> Yes	<input checked="" type="checkbox"/> No
If yes, specify the material.	Material:	
If yes, specify the weight% of the entire product.	Weight%:	

### Per- and polyfluoroalkyl substances (PFAS)

Does the product contain any per- and polyfluoroalkyl substances (PFAS) that has been purposefully added to achieve a specific function?	<input type="checkbox"/> Yes	<input checked="" type="checkbox"/> No
If yes, specify the material.	Material:	
If yes, specify the weight% of the entire product.	Weight%:	

### 3. Recycled raw material

Does the product contain recycled material?	<input type="checkbox"/> Yes	<input checked="" type="checkbox"/> No
If yes, specify in Table 3.		

If the product consists of recycled materials specify the material and the percentages of the total weight of the product, in *Table 3*, Recycled materials.

**Table 3.** Recycled material.

Material	Percentage (%) <i>Recycled material of the total product's weight</i>	Percentage (%) <i>of the recycled material that has not reached the consumer level, such as production waste, etc. (pre-consumer)</i>	Percentage (%) <i>of the recycled material that has reached the consumer level (post-consumer)</i>	Comments

### If wood raw material is included

Can the product be ordered with sustainability certificates for the wood raw material?	<input type="checkbox"/> Yes	<input type="checkbox"/> No
<p>If <i>yes</i>: Specify the percentage of wood raw material that is certified, what system has been used (e.g. FSC or PEFC) and give the license number for the certification.</p> <p>Attach the certificate together with the application.</p>		
<p>If <i>no</i>: Has wood raw material from documented sustainable forestry been used in the production of the product? If so, please indicate how much of the included wood raw material used that comes from documented sustainable forestry:</p> <p>Attach certificates from all subcontractors together with the application.</p>		
If sustainability certificates are missing, state the harvesting country for wood raw material:		
Is the wood species or origin in the CITES appendix for endangered species?	<input type="checkbox"/> Yes	<input type="checkbox"/> No

### 4. The production phase

Has an Environmental Product Declaration (EPD) according to ISO 14025 and EN 15804 (or equivalent for other product groups) been prepared?	<input type="checkbox"/> Yes	<input checked="" type="checkbox"/> No
Has another type of environmental product declaration been prepared?	<input type="checkbox"/> Yes	<input checked="" type="checkbox"/> No
If yes, enclose the EPD (Environmental Product Declaration) or any other environmental product declaration together with the application.		
Has an active choice been made, regarding the electricity supplier, to promote electricity production from renewable energy sources?	<input type="checkbox"/> Yes	<input checked="" type="checkbox"/> No
If yes, describe the type of energy source, percentage of energy stemming from the renewable source, how long the agreement has been applied (start and end date), electricity supplier, and for which part of the production it is valid for:		

## 5. Distribution of the completed product

Describe the management of packaging for the distribution of the product:  <i>Specify the packaging material used and which system of producer responsibility for packaging the supplier is affiliated to.</i>  <i>Enter the proportion of recycled material, if any, included in the packaging.</i>	Description of the packaging:  <b>No system for taking back or recycling of packaging.</b>  <b>The products are in plastic bag and cardboard box.</b>
Other information:	

## 6. Construction and usage phase

Are there any special requirements such as storage conditions etc. for the product during storage?	<input type="checkbox"/> Yes	<input checked="" type="checkbox"/> No	
If yes, describe:			
Are there any special requirements for adjacent building products because of this product?	<input type="checkbox"/> Yes	<input checked="" type="checkbox"/> No	
If yes, describe:			
Are there any operating/care instructions for the product?	<input type="checkbox"/> Yes	<input checked="" type="checkbox"/> No	
If yes, attach the documentation with the application.			
Is the product energy labelled in accordance with the Energy Labelling Directive (2010/30/EU)?	<input type="checkbox"/> Yes	<input checked="" type="checkbox"/> No	<input type="checkbox"/> Not relevant
If yes, state class (G to A, A+, A++, A+++):	Class:		

## 7. Waste management

Does the product require special measures to protect health and the environment in conjunction with demolition/dismantling?	<input type="checkbox"/> Yes	<input checked="" type="checkbox"/> No
If yes, describe:		
Is the product covered by the WEEE-directive 2012/19/EU (Swedish ordinance (2014:1075) on Producer Responsibility for electrical and electronic products when it becomes waste?	<input type="checkbox"/> Yes	<input checked="" type="checkbox"/> No
Is it possible to re-use all or parts of the product? (can the product be reused within the product's expected lifetime)?	<input type="checkbox"/> Yes	<input checked="" type="checkbox"/> No



If yes, describe:		
Is material recycling possible for all or parts of the product when it becomes waste?	<input checked="" type="checkbox"/> Yes	<input type="checkbox"/> No
If yes, describe:		
Is energy recycling possible for all or parts of the product when it becomes waste?	<input checked="" type="checkbox"/> Yes	<input type="checkbox"/> No
Does the supplier have any restrictions and recommendations for reuse, material- or energy recycling or disposal?	<input checked="" type="checkbox"/> Yes	<input type="checkbox"/> No
If yes, specify which: All metal parts can be re-melted and used as new raw material All plastic parts can either be re-grinded and used as new raw material or burned to give energy		
When the supplied product becomes waste, is it classified as hazardous waste?	<input type="checkbox"/> Yes	<input checked="" type="checkbox"/> No
If yes, specify the waste code: The Swedish waste ordinance (2011:927) <a href="https://www.notisum.se/rnp/sls/lag/20110927.htm">https://www.notisum.se/rnp/sls/lag/20110927.htm</a>	Waste code:	

## 8. Indoor environment

Has the product a critical moisture condition: <i>Information regarding whether critical moisture conditions leading to microbial growth apply for the material/product should be stated but will not impact the assessment.</i>	<input type="checkbox"/> Yes	<input checked="" type="checkbox"/> No
If Yes, specify which:		
Is the article (or chemical product) intended for indoor use?	<input checked="" type="checkbox"/> Yes	<input type="checkbox"/> No
If yes, has emission data been produced for volatile organic compounds?	<input type="checkbox"/> Yes	<input checked="" type="checkbox"/> No
If yes, attach the report/certificate together with the application.		
If <i>no</i> , is there any motivation for why emission data for volatile organic compounds is not relevant for the product?	Motivation: Mechanical products without any emission	

## Byggvarubedömningen's Certificate of substance content and concentrations, Version 6.0.

A correct and fully\* completed certificate is required for the possibility of reaching the Recommended assessment level for chemical contents. The certificate is required also when contents are reported in another document not drafted in accordance with the eBVD15 requirements (for example, when contents are reported in a BVD3).

\*Obligatory data required for the certificate to be considered fully completed.

The certificate is for the following products (product name on the application): *	
<i>(The name of the product/item is to be identical with the name stated when applying for assessment. The certificate can be used for several assessments.)</i>	
RA-N & RA-U Pure and accessories	
It is certified for the above products that (choose alternative A1, A2, B1 or B2): *	
A1 <input type="checkbox"/>	<p>It is hereby certified that:</p> <ul style="list-style-type: none"> <li>Concentrations of the constituent substances have been reported <b>down to a percentage by weight (wt%) of 0,01.</b> <i>(This implies a complete declaration of contents in which all substances present in concentrations of <math>\geq 0,01</math>wt% have been reported.)</i></li> <li>Substances that are subject to specific concentration limits <math>&lt; 0,01</math> wt%: These substances are reported if they occur in concentrations up to 10 times lower than their specific concentration limit. <i>(This means that if a substance's specific concentration limit is 0,0015 wt%, concentrations <math>\geq 0,0015</math> wt% are to be reported.)</i></li> <li>Actively added or contamination of mercury has been reported regardless of concentration.</li> <li>Cadmium is reported in cases of <math>\geq 0,001</math> wt%.</li> </ul>
B1 <input checked="" type="checkbox"/>	<p>It is hereby certified that:</p> <ul style="list-style-type: none"> <li>Concentrations of the constituent substances have been reported <b>down to 0,1 wt%.</b> <i>(This implies a complete declaration of contents in which all substances of concentrations <math>\geq 0,1</math>wt% have been reported.)</i></li> <li>Substances that are subject to specific concentration limits <math>&lt; 0,1</math> wt% have been reported when they occur. <i>(This means that if a substance's specific concentration limit is 0,0015 wt%, concentrations <math>\geq 0,0015</math> wt% are to be reported.)</i></li> <li>Actively added or contamination of mercury has been reported regardless of concentration.</li> <li>Cadmium is reported in cases of <math>\geq 0,01</math> wt%.</li> </ul>
I have not reported according to alternative A1 or B1, but I have followed the instructions for Declaration of content, Byggvarubedömningen's reporting requirements 2021-1 (Annex 1. Table 1):	

A2 <input type="checkbox"/>	Equivalent to <i>Recommended</i> level.
B2 <input checked="" type="checkbox"/>	Equivalent to <i>Accepted</i> level.
<i>It is further certified for the above specified products (choose alternative C or D): *</i>	
C <input checked="" type="checkbox"/>	It is hereby certified that "Specifically indicated substances" in accordance with Annex 1, Table 2 have not been added during production or been formed through reactions between the substances in the product.
D <input type="checkbox"/>	Unfortunately, we have to notify that the specified products contain "Specifically indicated substances" in accordance with Annex 1, Table 2. One/some of these substances have been added during production or have been formed through reactions between the substances in the product, refer to the reported Declaration of content.

I hereby certify that the above data is correct to my best knowledge. \*

Person responsible for the declaration: *	<b>Søren Holm Sørensen</b> <b>Design Engineer</b>
Signature: **	<i>Søren H. Sørensen</i>
Contact details (email, phone): *	<b>Søren Holm Sørensen</b> <b>SHS@Danfoss.com</b>
Place and date: *	Viby 2022.05.16

\* Obligatory data required for the certificate to be considered fully completed.

\*\* Voluntary data that may be a requirement in, for example, certain certification systems.

If you want your logotype on the certificate, paste it below:

## Annex 1. Declaration of content, Bygghvarubedömningen's reporting requirements, 2021-1.

An assessment is based on the complete contents of an item or a chemical product on delivery stated as wt% of the entire product.

For the Accepted and Recommended levels, classified substances must be reported in the documentation if concentrations exceed limits (wt%) in accordance with Table 1, Classified substances. Substances that are not included under Table 1 must always be reported when concentrations of  $\geq 2\%$  occur. Reporting requirements for the Accepted level correspond to the eBVD15 requirements.

Contents can be specified in concentration intervals, and the assessment is then done based on the concentration that gives the strictest assessment. Examples of accepted intervals are:  $\leq 1\%$ , 1–2,5%, 2,5–10%, 10–25%, 25–50%, 50–75%, and 75–100%. More information about what can be included in the same assessment is in the next section.

For chemical products, concentrations specified in the safety data sheet are governing, which means that the interval specified in a building product declaration must include that specified in the SDS.

Note that for a content to be considered fully reported, at least 98% of the product must be declared. Reports in which  $< 98\%$  is reported will be accepted if it is also evident that other substances/materials contribute  $< 2\%$  each and do not have properties according to Table 1. These can instead be reported with their function (filler  $< 2\%$ , additive  $< 2\%$ , etc.).

If classification is applied that is not covered by harmonised classification, this information must be provided in the declaration of contents for that substance and the assessment will be done on that basis.

For the possibility of achieving the Recommended assessment level for chemical contents, the product may contain no specifically indicated substances/substance groups, regardless of concentration, refer to Table 2.

**Table 1.** Reporting requirements for constituent substances. Note that the below only applies to reporting of substance contents. The complete assessment criteria are available on the website (<https://byggvarubedomningen.se/dokument/>). The table for reporting toward Accepted assessment level follows the eBVD15 requirements with an amendment for requirements concerning endocrine disrupting substances, see below.

<i>Every constituent substance is to be reported as wt% of the entire product if it is equal to or more than the below reporting limits. If wt% is specified at component level, also the component's wt% of the entire product must be specified.</i>		
Classification/listing	Reporting limit Accepted	Reporting limit Recommended
Carcinogenic, Category 1A or 1B (H350)	0,1%	0,01%
Carcinogenic, Category 2 (H351)	1%	0,1%
Mutagenic, Category 1A or 1B (H340)	0,1%	0,01%
Mutagenic, Category 2 (H341)	1%	0,1%
Reproductive toxicity, Category 1A or 1B (H360)	0,3%	0,03%
Reproductive toxicity, Category 2 (H361)	2%	0,3%
Reproductive toxicity, effects on or via lactation (H362)	0,3%	0,03%
Endocrine disruptors <sup>1,2,3</sup>	0,1%	0,01%
PBT and/or vPvB substances <sup>4,5</sup>	0,1%	0,01%
Ozone depleting substances (EUH 059, H420)	0,1%	0,01%
Sensitisation, respiratory category 1A (H334)	0,1%	0,01%
Sensitisation, respiratory category 1 or 1B (H334 solid/liquid)	1%	0,1%
Sensitisation, respiratory category 1 or 1B (H334 gas)	0,2%	0,02%
Sensitisation, skin category 1A (H317)	0,1%	0,01%
Sensitisation, skin category 1 or 1B (H317)	1%	0,1%
Acute toxicity, Category 1 (H300, H310, H330, H301, H311 and/or H331)	0,1%	0,01%
Acute toxicity, Category 2 (H300, H310, H330, H301, H311 and/or H331)	1%	0,1%
Acute toxicity, Category 3 (H300, H310, H330, H301, H311 and/or H331)	2%	1%
Specific Target Organ Toxicity – Single Exposure (STOT-SE), Category 1 (H370)	1%	0,1%
Specific Target Organ Toxicity – Repeated Exposure (STOT-RE), Category 1 (H372)	1%	0,1%
Hazardous to the aquatic environment, Chronic Category 1 (H410)	2%	0,25%
Potential vPvB and PBT substances <sup>6</sup>	2%	0,1%
Fluorinated greenhouse gases	0,1%	0,01%
Candidate list, to be reported at component level <sup>7</sup>	0,1% (component level)	0,01% (component level)
Pure or compounds of lead (Pb)	0,1%	0,01%

Pure or compounds of mercury (Hg)	Contamination $\geq$ 2.5 mg/kg (ppm) and any active added mercury must always be reported.	
Pure or compounds of cadmium (Cd)	0,01%	0,001%
Substances covered by any of the above specified classifications, but which are also covered by specific concentration limits in accordance with CLP.	According to specific concentration limits if lower than specified above <i>(Applies to, for example, certain preservatives)</i>	10 times lower than specific concentration limit
Other classifications, and unclassified substances and material	2%	2%
<p><i>References</i></p> <p><sup>1</sup>EU's EDS Database, Cat 1 &amp; 2 <a href="http://ec.europa.eu/environment/chemicals/endocrine/strategy/being_en.htm">http://ec.europa.eu/environment/chemicals/endocrine/strategy/being_en.htm</a></p> <p><sup>2</sup>Chemsec's SIN Lista, EDC Substances <a href="https://sinlist.chemsec.org/search/search?query=&amp;healthenvironmentconcerns=1">https://sinlist.chemsec.org/search/search?query=&amp;healthenvironmentconcerns=1</a></p> <p><sup>3</sup>Candidate List, endocrine disrupting substances <a href="https://echa.europa.eu/sv/candidate-list-table">https://echa.europa.eu/sv/candidate-list-table</a></p> <p><sup>4</sup>Substances that meet the criteria for PBT/vPvB in accordance with KEMI, PRIO <a href="https://www.kemi.se/prio-start/criteria/the-criteria-in-detail/pbtvpvb">https://www.kemi.se/prio-start/criteria/the-criteria-in-detail/pbtvpvb</a></p> <p><sup>5</sup> Candidate List, PBT/vPvB substances <a href="https://echa.europa.eu/candidate-list-table">https://echa.europa.eu/candidate-list-table</a></p> <p><sup>6</sup> Substances that meet the criteria for potential PBT/vPvB substances in accordance with KEMI, PRIO <a href="https://www.kemi.se/prio-start/criteria/the-criteria-in-detail/potential-pbtvpvb">https://www.kemi.se/prio-start/criteria/the-criteria-in-detail/potential-pbtvpvb</a></p> <p><sup>7</sup>Substances on the Candidate List, <a href="https://echa.europa.eu/candidate-list-table">https://echa.europa.eu/candidate-list-table</a>. For composite products, substances on the Candidate List are required by law to be reported at component level. Information about this can be found on ECHA's website <a href="https://echa.europa.eu/regulations/reach/candidate-list-substances-in-articles">https://echa.europa.eu/regulations/reach/candidate-list-substances-in-articles</a>.</p> <p><i>(If the above links do not work, it may be because they have been updated, which is beyond Byggarubedömningen's control. Updates of non-functioning links will be corrected as soon as possible after they have been discovered.)</i></p>		

**Table 2.** Specifically indicated substances may not have been added to the product during production or formed through reactions between the substances in the product to qualify for Recommended assessment level.

<i>Substance group/Substance</i>
Arsenic and its compounds <sup>1</sup>
Brominated flame retardants
Per- and polyfluoroalkyl substances (PFAS)
Organotin compounds
Biocidal product applied on products (surface treatments) to provide a disinfectant or anti-bacterial effect.
<sup>1</sup> Arsenic, or arsenic compounds, are not permitted to be added to the product. Contamination of used raw materials is not permitted to exceed 10 mg/kg. The concentration limit is set based on regulatory requirements for soil quality to ensure that products assessed as Recommended do not raise background concentrations through their use or disposal (for example; sludge from sewage

treatment works Swedish Ordinance 1998:944, Section 20). The same concentration limits are found in the Swedish Environmental Protection Agency's general guidelines for sensitive land use <https://www.naturvardsverket.se/Stod-i-miljoarbetet/Vagledning/Fororenade-omraden/Riktvarden-for-fororenad-mark/> .

### What may be included in the same assessment?

Generally, an assessment is done for a single item or chemical product. However, an assessment can also be done for a product series given that the included articles are covered by the same declaration of contents. Contents are then provided in intervals, and the assessment is done based on the concentration that gives the strictest assessment. Unclassified substances and material that contribute <2% and that differ between the products in a series can be subject to the same supporting documentation and assessment. Consequently, intervals specified as 0 – ≥2% are generally not accepted for a product series (well-founded exemptions can be accepted following control questions from an assessor). For chemical products, all articles included in the assessment are covered by the same safety data sheet.

For two or multi-component products, each component requires its own assessment and separate assessment documentation. According to current legislation, each component is to be reported in two separate safety data sheets. Exemptions may be made if the products are packaged in such a way that they cannot be separated. If so, information for both components can be provided in the same safety data sheet if it can be clearly determined which information applies to which component. Criteria that address issues where the components are hardened are assessed based on the hardened product's characteristics (for example, leaching, waste and emissions). For multi-component products, it should be clearly evident in the product description with which other products the individual components are intended to be used.

### Descriptions of material

Constituent substances are to be reported with their CAS number and/or EC number. Exemptions can be made for certain materials in accordance with the following instructions.

Alloys are to be reported with the alloy number. Alternatively, constituent substances over 0,01% of the alloy are to be reported. For unspecified alloys, the following exemptions are made (which may affect the assessment result):

- Stainless steel, the assessment is based on the alloy containing 10% nickel.
- Brass, the assessment is based on the alloy containing 3% lead.
- Aluminium, the assessment is based on the alloy containing 1,5% lead.

Plastics and rubber materials are to be reported together with their name so that it is clear which monomers are included, for example, acrylonitrile butadiene styrene (ABS), polyethylene (PE), etc. Any residual monomers need not be reported.

Examples of plastics/polymers that are accepted without specification of constituent monomers:

- Polycarbonate (pertains to bisphenol A based polycarbonates)
- Polyester (monomers must be specified for halogenated polyesters)
- Polyurethane (monomers must be specified for halogenated polyurethanes)
- Fibreglass reinforced epoxy resin laminates FR4 (pertains to tetrabromobisphenol A based polymers)
- MS polymers (refers to silane-modified polyether)

Examples of plastics, polymers and rubber material that require clarification:

- Polymer dispersion
- Copolymer
- Thermoplastic elastomers (TPE)
- Thermoplastics
- Silanes. The type of polymer must be specified, for example, whether it refers to a silane/silyl-modified polyether or polyurethane.
- PVC. For concentrations  $\geq 2\%$ , plasticizers must always be reported with the CAS number and concentration. Less than 2%, plasticizers subject to the reporting limits specified in Table 1 are to be reported. If no plasticizer is specified, the assessor will check with the supplier regarding the occurrence of plasticizer classified as endocrine disrupting and other classification requirements.
- EPDM and SBR rubber. For concentrations  $\geq 2\%$ , mineral/paraffin oil must always be specified with the CAS number and concentration. Alternatively, the PAH content can be specified.
- For plastics and rubber material that come into direct as well as prolonged or short-term repetitive contact with the human skin or the oral cavity under normal or reasonably foreseeable conditions of use, the concentration limit is to be fulfilled in accordance with the PAH Regulation (European Commission's Regulation (EU) No. 1272/2013 to amend Annex XVII of the European Parliament and of the Council concerning the Registration, Evaluation, Authorisation and Restriction of Chemicals Regulation (EC) No. 1907/2006 (REACH) on the restrictions of polycyclic-aromatic hydrocarbons ( <https://eur-lex.europa.eu/legal-content/EN/TXT/PDF/?uri=CELEX:32013R1272&from=> ).
- Expanded polystyrene (EPS), cellular plastic, is assumed to always contain 2% pentane unless otherwise specified. If pentane content  $< 1\%$  of the constituent EPS is reported, this must be verified with analysis data.

*Additives that have not formed polymers must always be reported in accordance with the reporting limits in Table 1 (for example, this applies for pigments, plasticizers, stabilizers, etc.).*

Examples of other materials that may require clarification:

- Glass (content of lead must be reported for the Recommended assessment level; relevant for recycled glass)



- Concrete (elements of any polymers are to be reported separately)
- Mineral fillers, pigments, etc.
- The PAH content must be reported when asphalt/bitumen is reported  $\geq 10\%$  for the possibility of reaching the Recommended assessment level.
- Electronic products are assumed to always contain brominated flame retardants and therefore cannot reach the Recommended assessment level.
- Flame retardants and any plasticizers are to be specified for cables.
- For impregnated wood, an enclosed safety data sheet for impregnating agents is required.

References can be given for composite products to other products (subcomponents) that have been assessed in Byggvarubedömningen's system and which have been provided with a BVVID. The referenced assessment must be current and not covered by a non-disclosure agreement (NDA). Non-public information may be used after confirmation from the concerned producer.